

Multiscale Approaches toward sustainable development

Tony Bi

**Clean Energy Research Centre (CERC) &
Department of Chemical & Biological Engineering
The University of British Columbia
Vancouver, Canada**

June 2, 2005

Outline

- I. Sustainability & sustainable development
- II. Evolution toward “Cleaner production”
- III. Evolution toward sustainable development
- V. Summary

I. Sustainability & sustainable development

Means industrial progress that meets the needs of the present without compromising the ability of future generations to meet their own needs

Four dimensions of sustainability

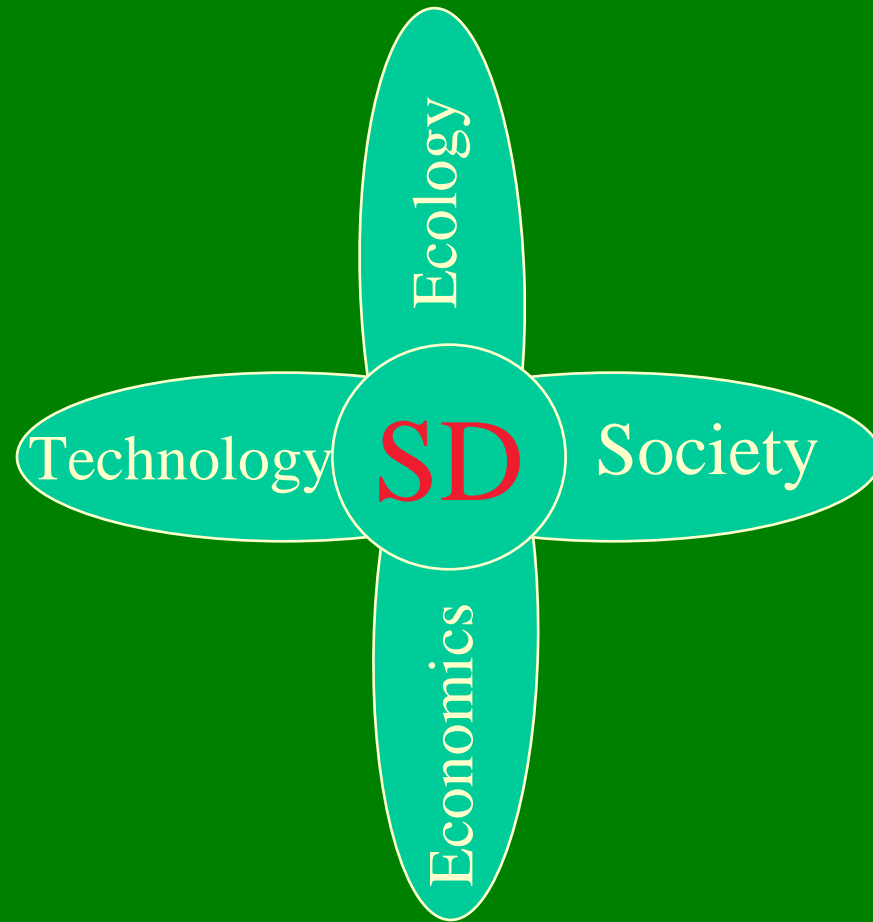

SD: Sustainable development

Roles of Technology

The overall environmental impact (EI) for a region or the world can be expressed (Graedel and Allenby, 2003) as,

$$\mathbf{EI = [Population] \times [GDP/person] \times [EI/GDP]}$$

- ❖ The first term is a social issue, and has been showing clearly the upward trend in all countries.
- ❖ The second term reflects the improvement of the human living standard, and also shows the growing trend, especially in developing countries like China.
- ❖ The last term is primarily a technological term, which offers the greatest hope for a transition to sustainable development.

II. Evolution toward “cleaner production”

Pollution Prevention (P2)

- ❖ **Means to avoid and/or eliminate the source of waste and to reduce the risk to human beings and the environment.**
- ❖ **Includes source reduction and in-process recycling.**

Example 1

Pollution prevention in the synthesis of linear alkylbenzene (LAB)

- ❖ Used for the manufacture of detergents
- ❖ Traditional process

HF, AlCl_3 or
 H_2SO_4



Corrosive
Environmental pollution

- ❖ New process

Solid acid catalyst



Elimination of corrosive
HF and H_2SO_4

Example 2

In-process recycling

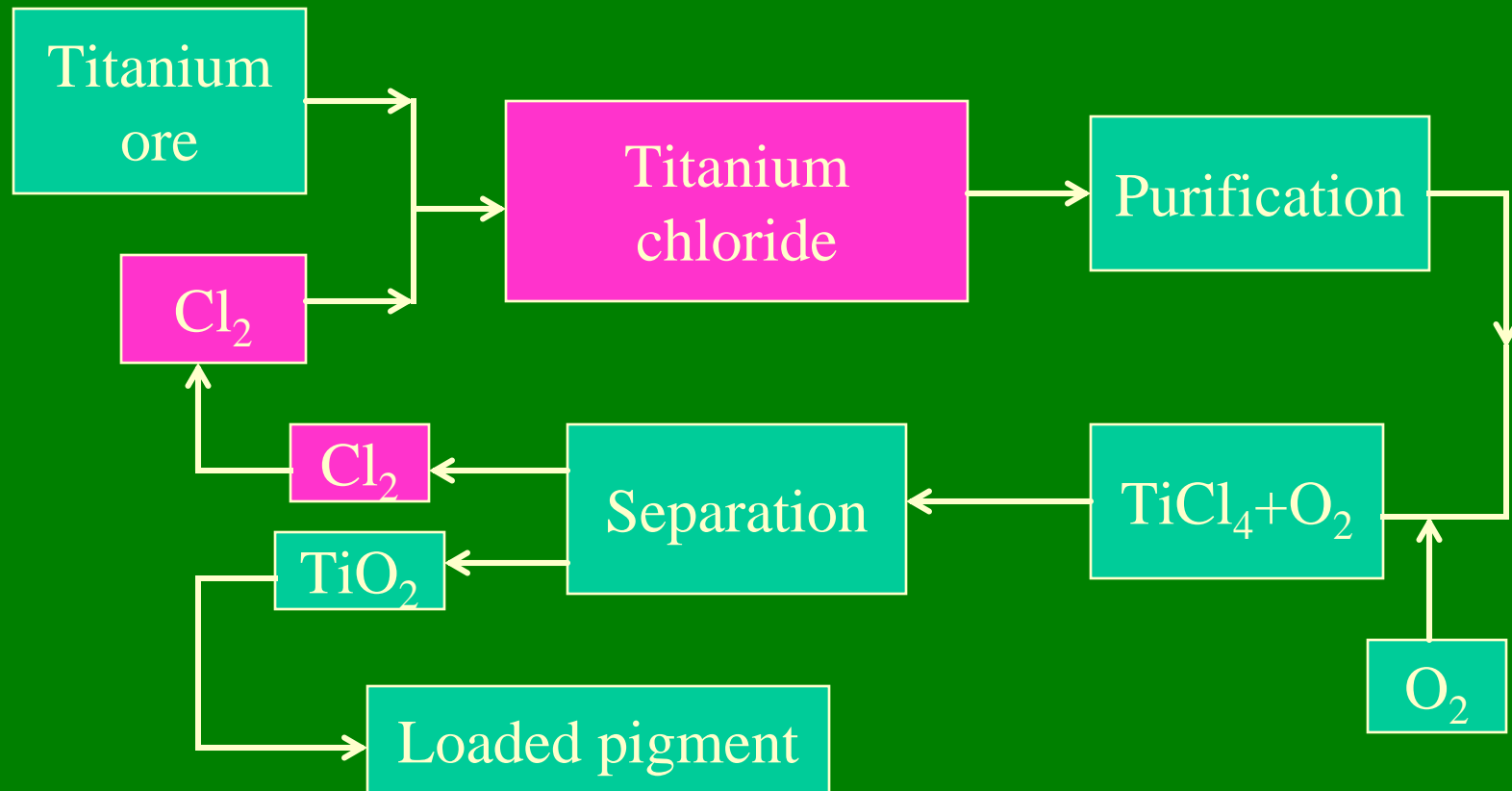

Industrial Ecology (IE)

- ❖ Examine the patterns of energy and materials of a product or an industrial system (plants, industrial complexes or communities) with the objective of prevention or minimization of waste generation.
- ❖ Offer a systematic view of industrial operations and transform industrial systems as close as possible to a closed-loop model.

Eco-industrial parks

Enhance economical and environmental performances by the optimal *integration of mass-energy-information flows* in industries.

Examples:

- ❖ Kalundborg Industrial Park, Denmark (70~90s)
- ❖ Four exemplar EIP sustained by PCSC, USA (1994)
- ❖ PALME plan, France (1995)
- ❖ Renovation of old Burnside IP, Canada (1990s)
- ❖ Zero discharge IP, Japan (Osaka 2001)
- ❖ Demonstration EIP, China (Taiyuan, Zaozhuang, Quzhou 2000)

Zaozhuang Eco-Industrial Park (Option 1)

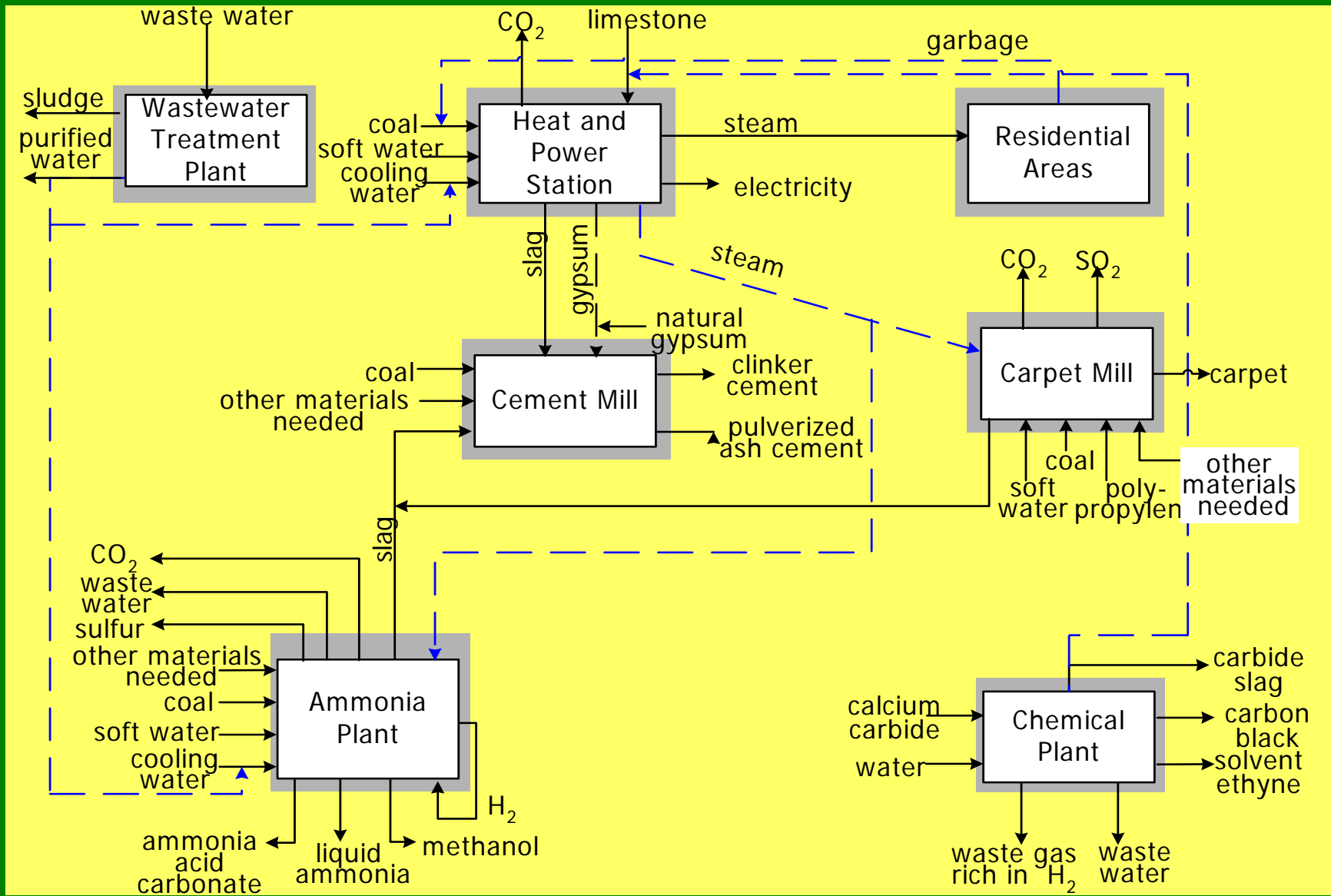

Zaozhuang Eco-Industrial Park (Option 2)

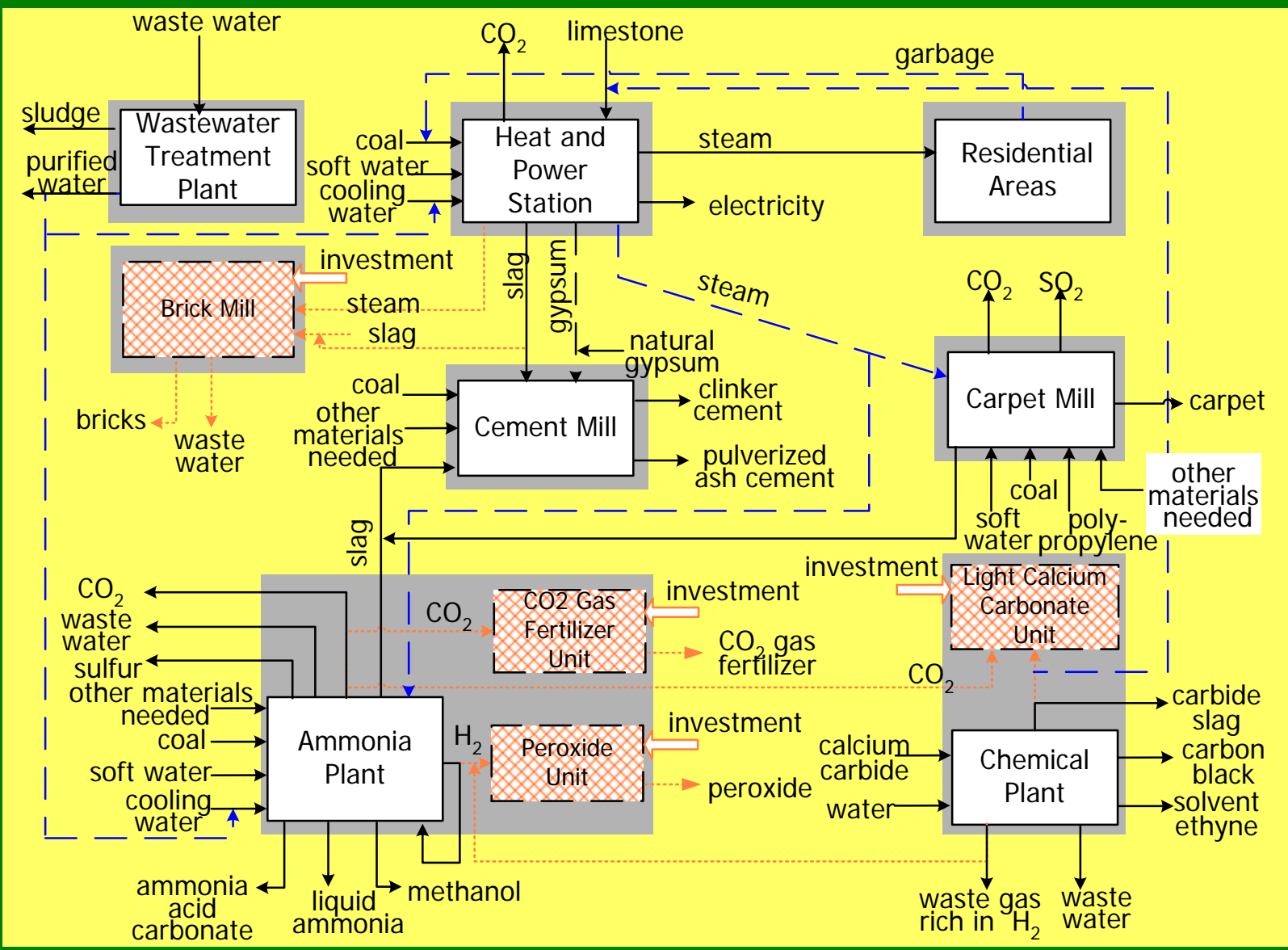

Green Engineering

- ❖ Design, commercialization and **use** of processes and **products**, which are **feasible** and **economical** while minimizing impact on **ecosystems** over the full **life cycle**.

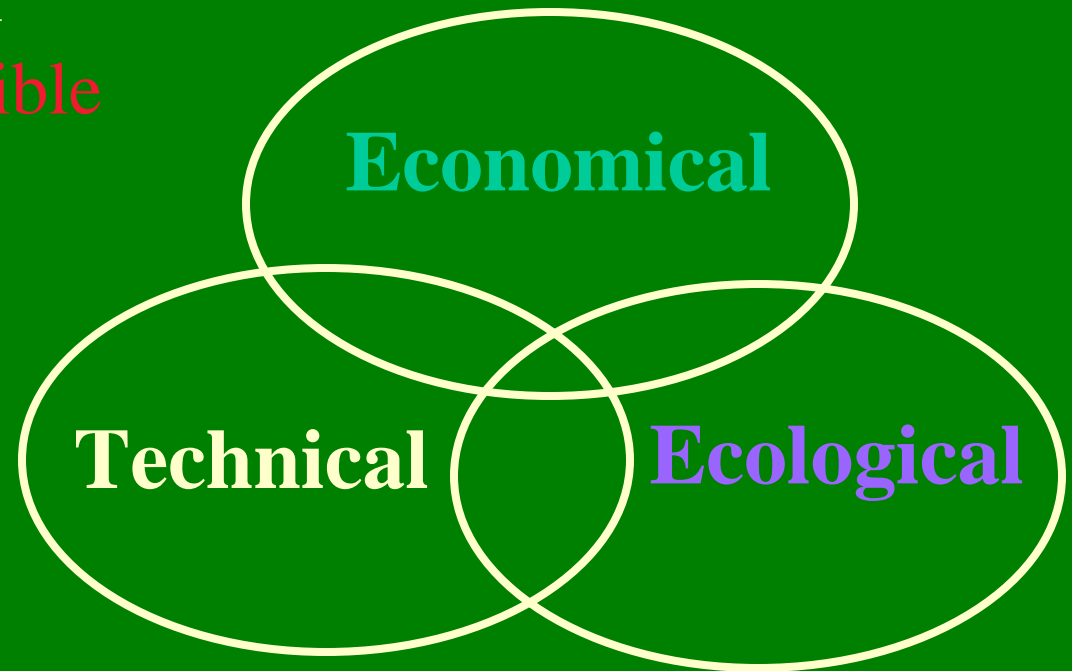

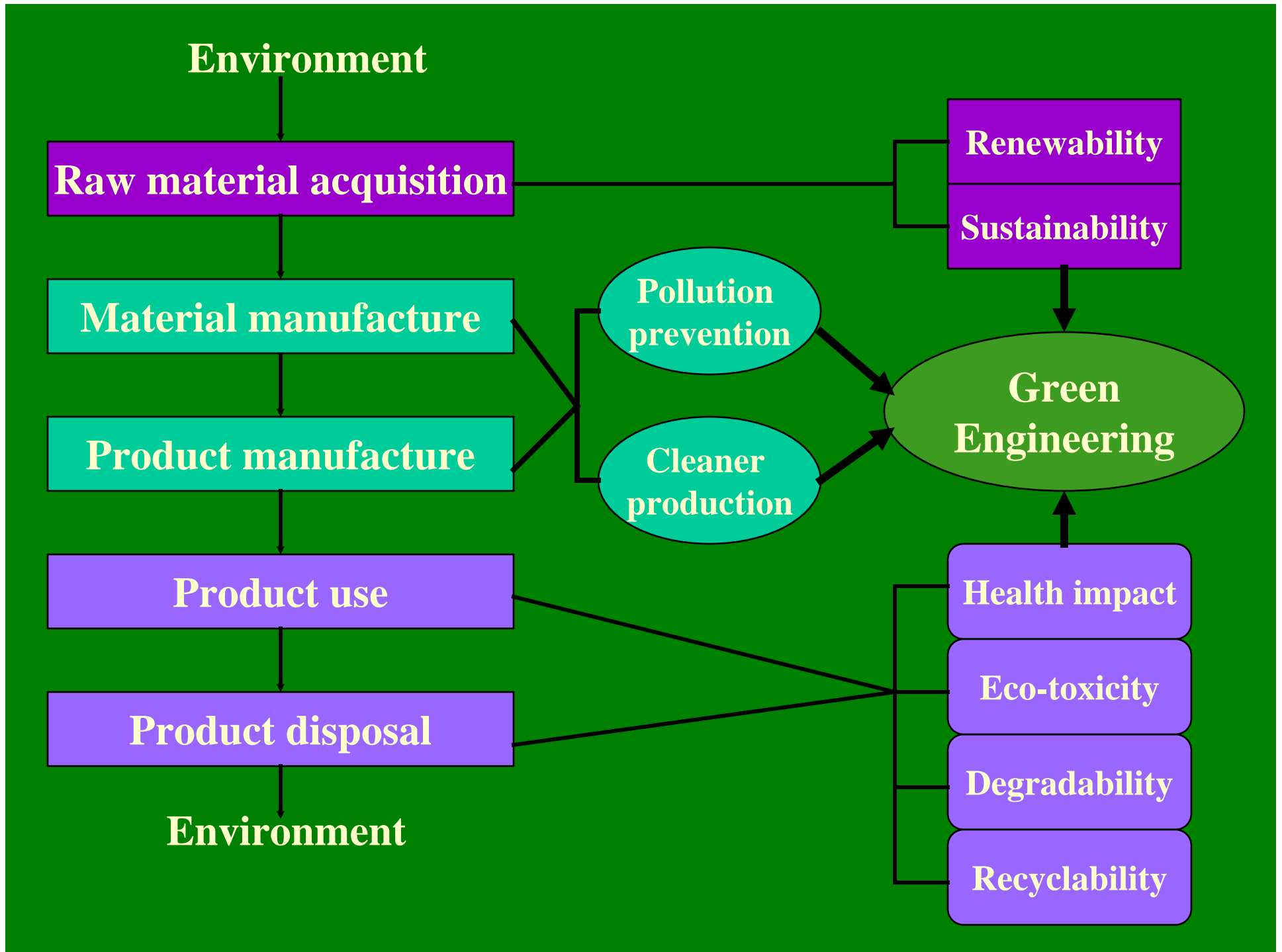

Example 4

Hydrogen Economy

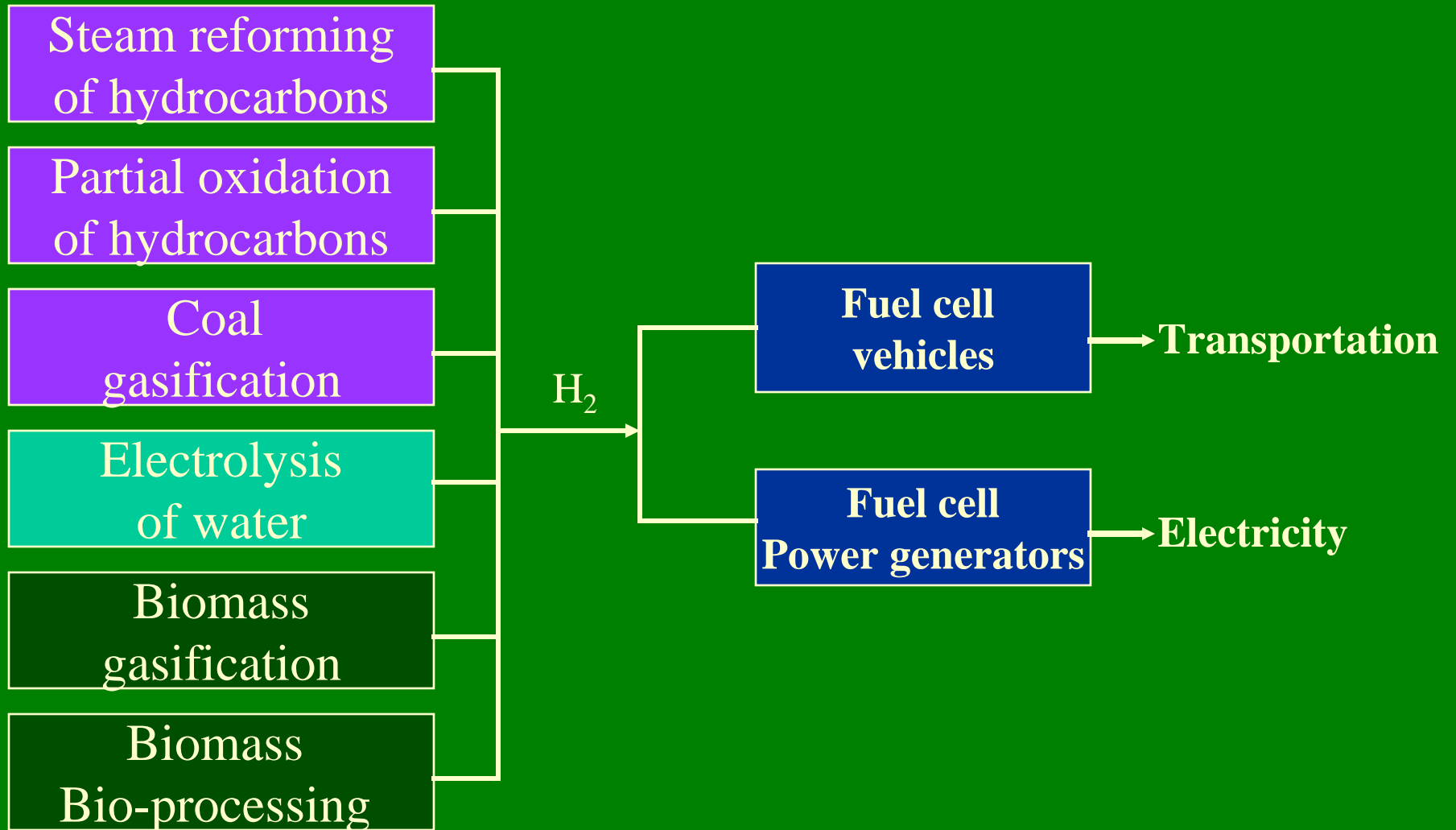

A vehicle-based LCA analysis

A simple LCA analysis (Lin, 2004)

	ICEV	EV	FCV	ICEV	Hybrid V
	TOYOTA RAV4- 2002	TOYOTA RAV4-EV- 2003	HONDA FCV-2003	HONDA CIVIC HX- 2002	HONDA CIVIC 2004
Pollutants	g/km	g/km	g/km	g/km	g/km
CO ₂	261	299	176	196	103
CH ₄		1.09	0.85		
N ₂ O		0.002	0.004		
CO	6.11	0.18	0.10	5.5	2.9
SO _x	1.58	1.01	0.23	1.06	0.56
NO _x	1.39	0.79	0.27	1.06	0.56
NMHC	0.65	0.29	0.23	0.47	0.25
PM	0.11	0.01	0.05	0.07	0.04

- ❖ Honda FCV – 50 miles/kg H₂; Honda Civic HX – 32 miles/G; Honda Civic Hybrid – 57 miles/G.

Example 5

“Smart” fertilizers

- ❖ Pollution prevention or cleaner production in making the fertilizer is very effective, but it cannot predict the emissions after the fertilizer is sold to the farmers who then spray it all over the farmland.
- ❖ **Problems:** low utilization ratio for
 - phosphate 10-20%
 - nitrogenous fertilizer 30-40%
 - potash fertilizer 35-50%
- ❖ **Causes:** release rate \gg absorption rate by crops
- ❖ **Solutions:** balancing these two rates by fertilizer coating
- ❖ **Benefits:** Resources conservation, reduction on water pollution and ecosystem damage

III

Multiscale engineering approach
toward
sustainable development

Multiscale and Multidisciplinary approaches

- ❖ Microscale: Green chemistry (Chemists)
- ❖ Mesoscale: Green engineering (Engineers)
- ❖ Macroscale: Eco-industrial parks, complex, networks, communities (Systems Engineers, Environmental Engineers, Ecological Scientists, social scientists, government officials)
- ❖ Global scale: Sustainable development (Planners, Economists, lawyers, government officials)

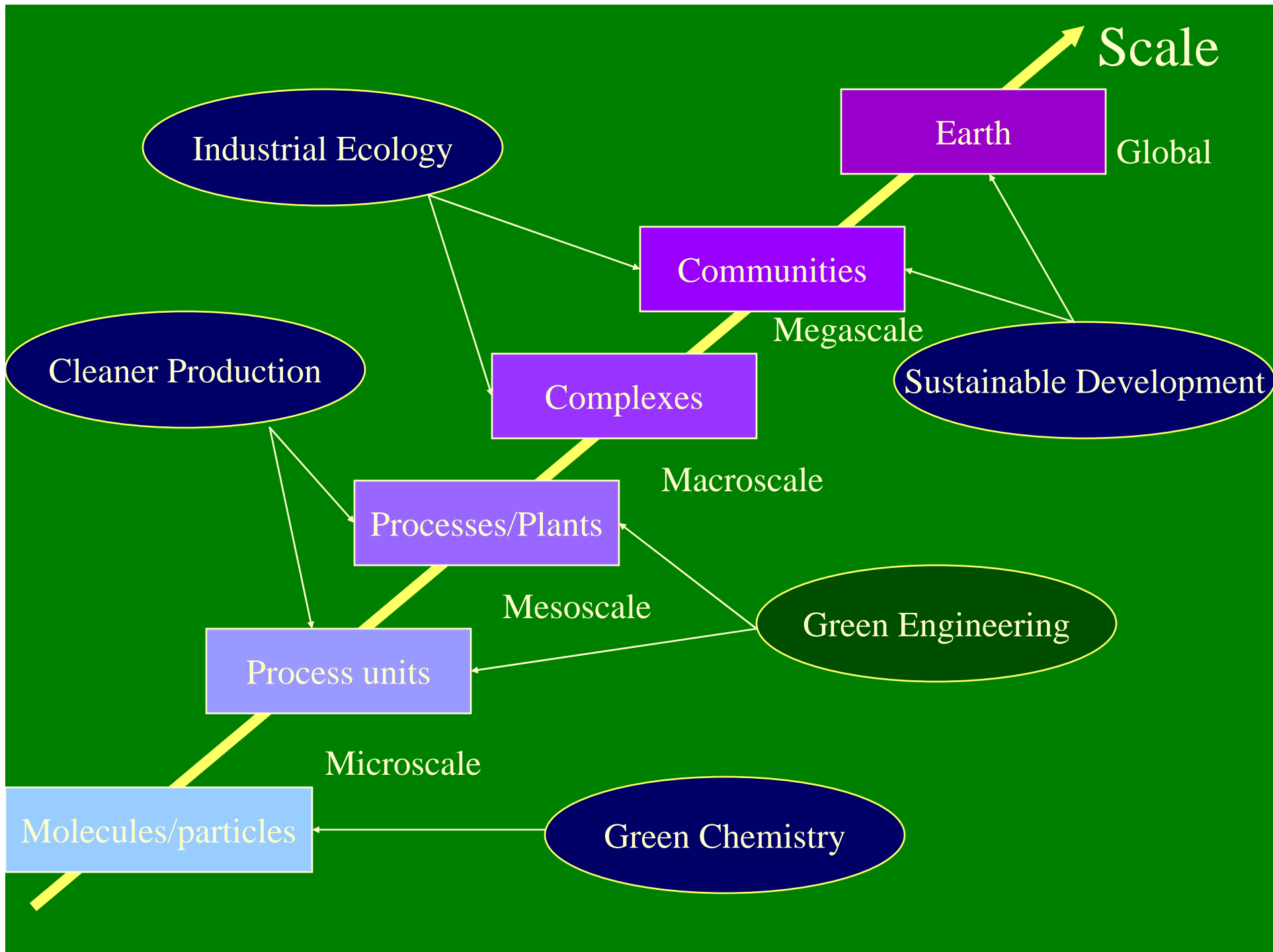

Multiscale Engineering Approaches

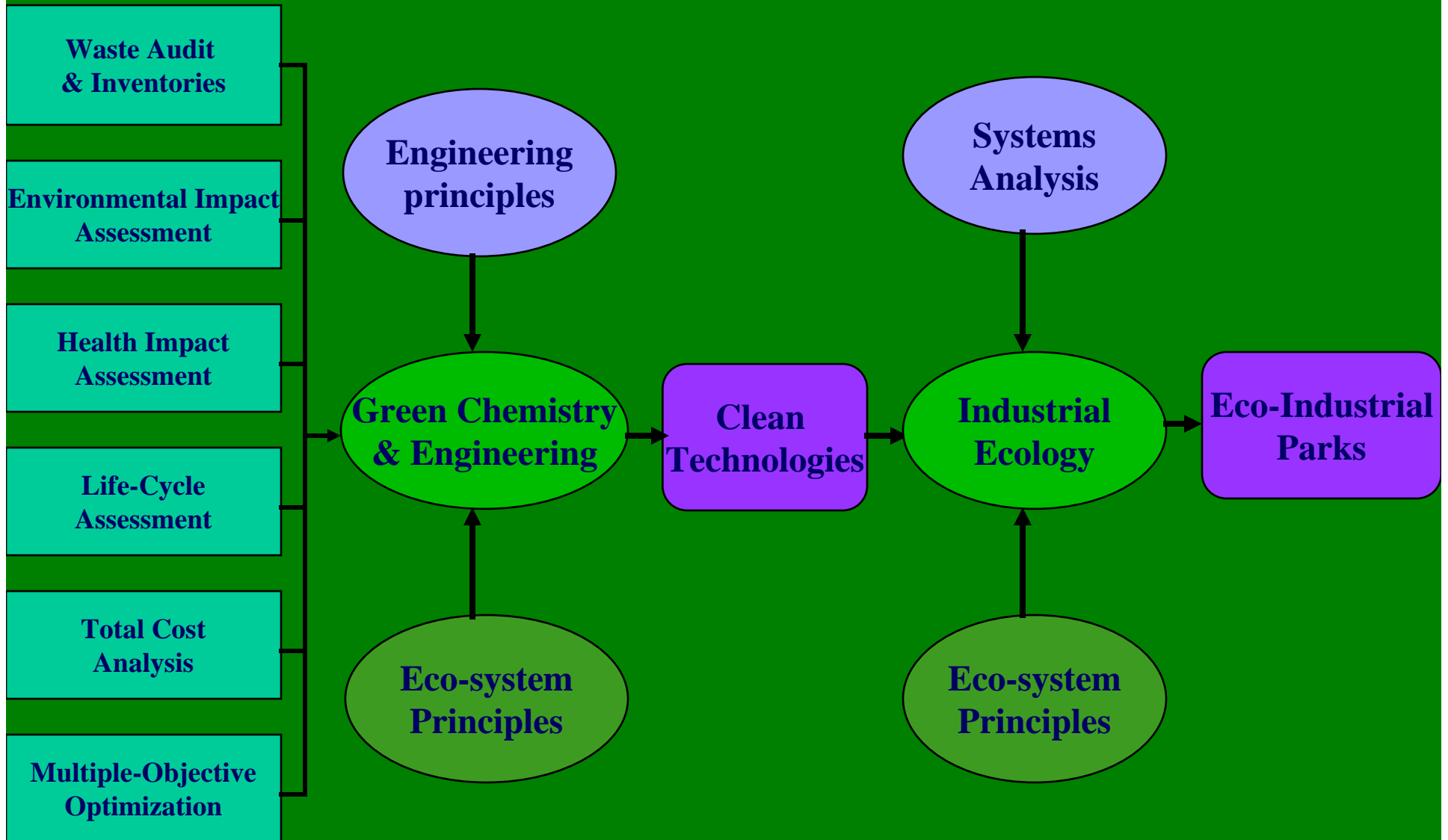

Example 6

Development of a sustainable regional agricultural eco-system

Animal waste management

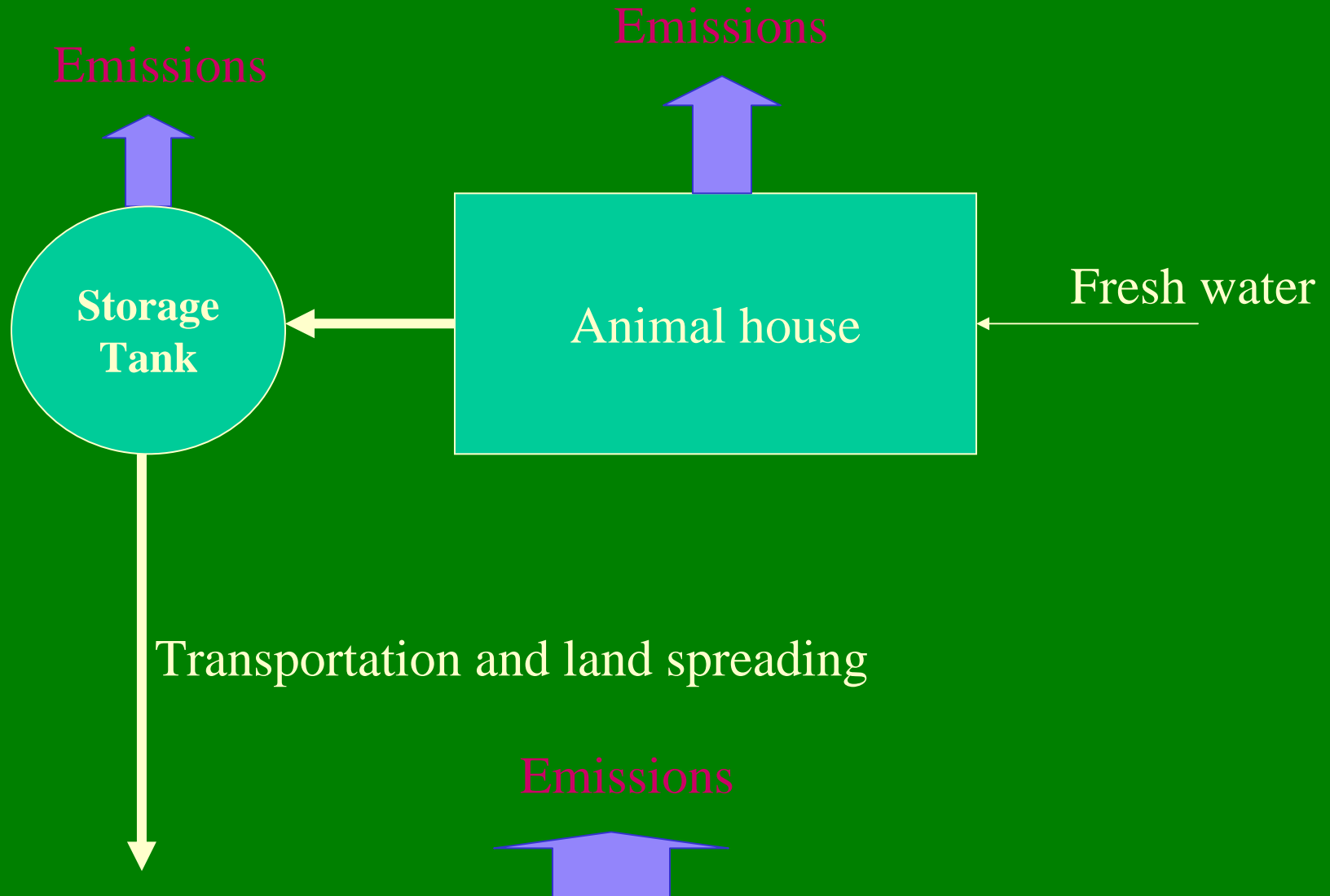

Underground water contamination

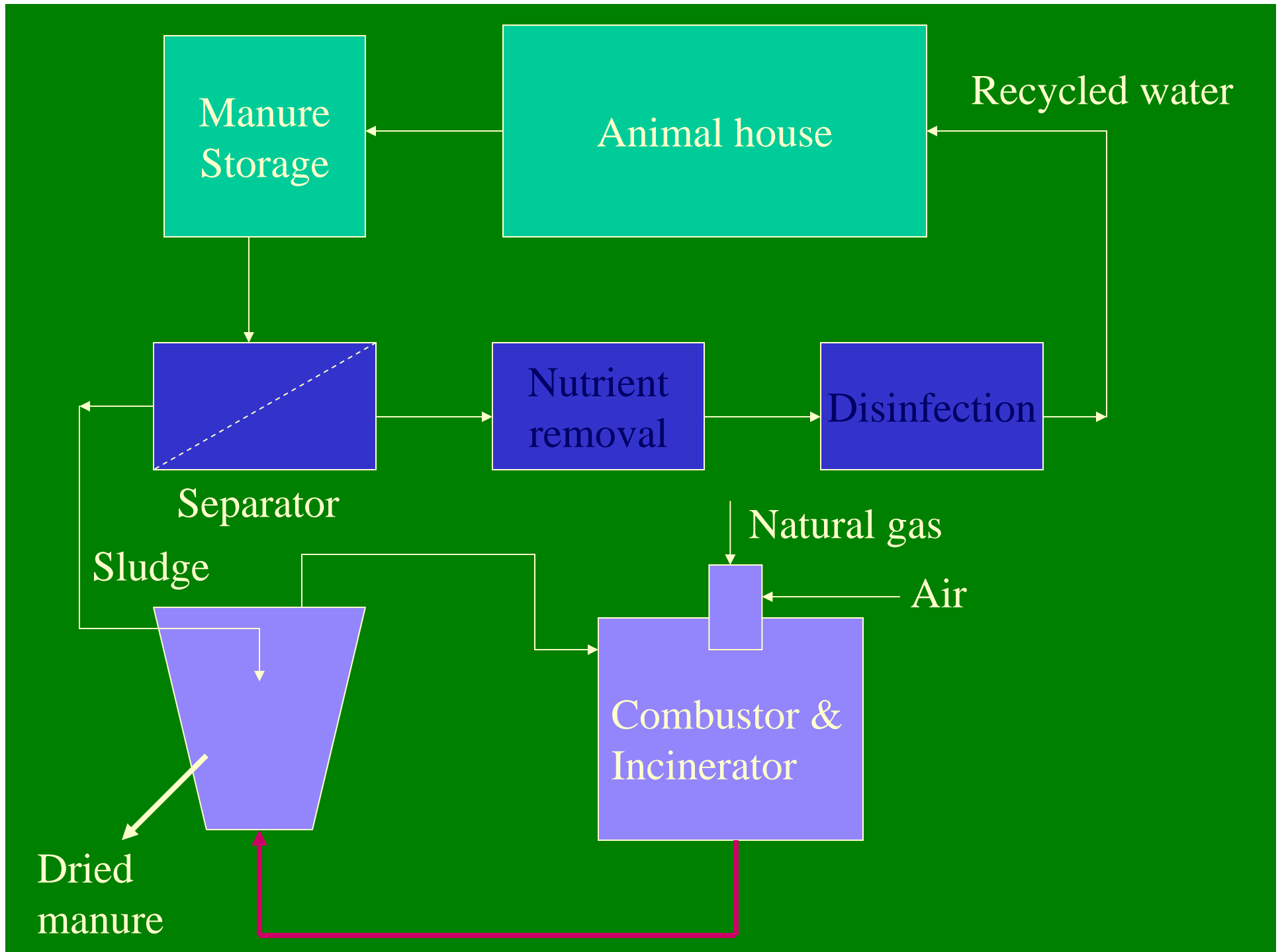

Alternative energy for green houses

- ❖ Greenhouse industry is a fast growing and energy-intensive industry in Canada. The average greenhouse requires 12 GJ per acre per year primarily from natural gas combustion for providing both heat and CO₂ for stimulating plant growth, with a total carbon dioxide emission in the order of 2.5 million tones per year.
- ❖ The use of renewable energy will reduce the energy cost and lead to significant reduction of greenhouse gas emissions.

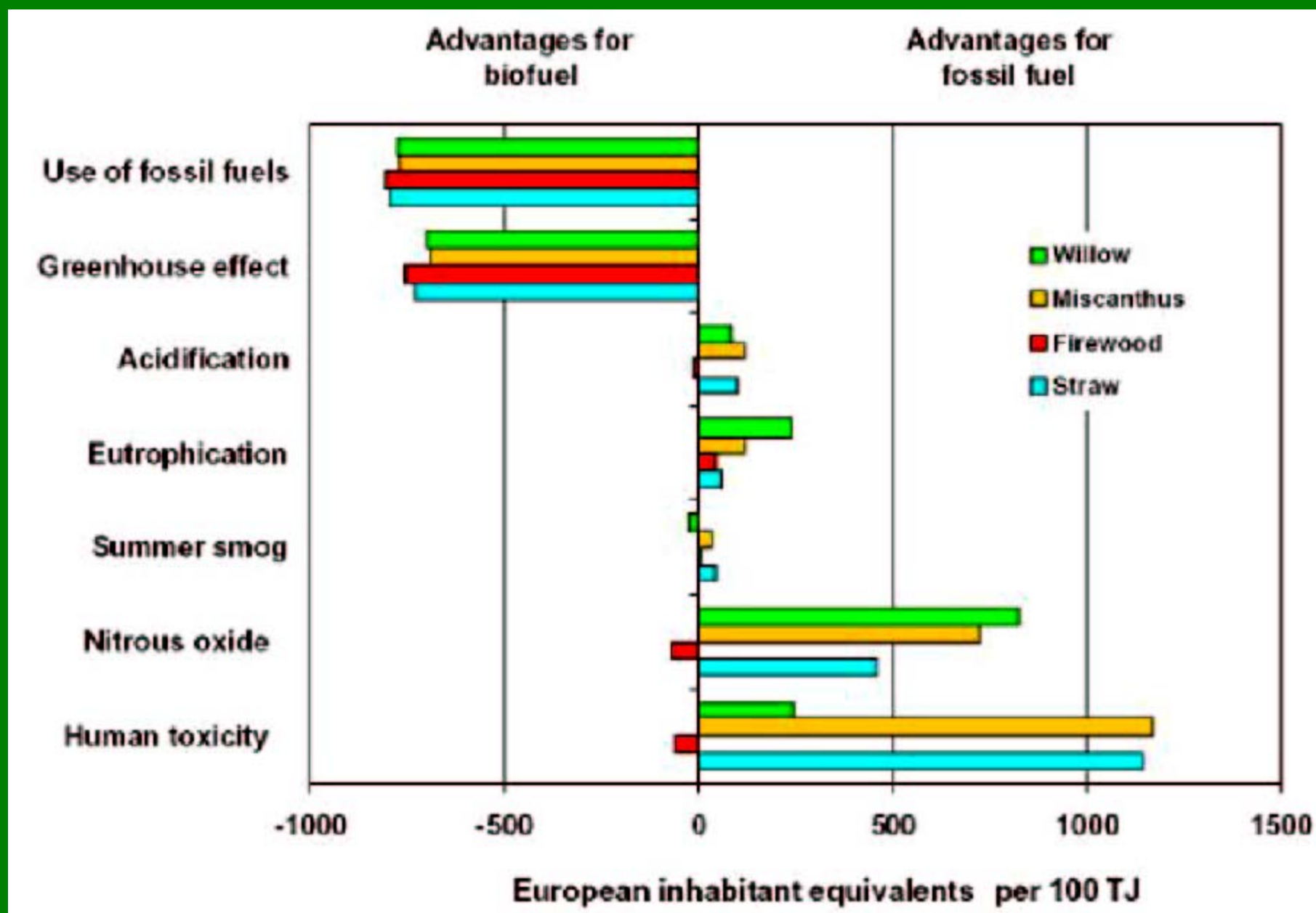

Calzoni et al. (2000). Bioenergies for Europe: which one fits best?

A multiscale approach: integration of green houses and animal farms

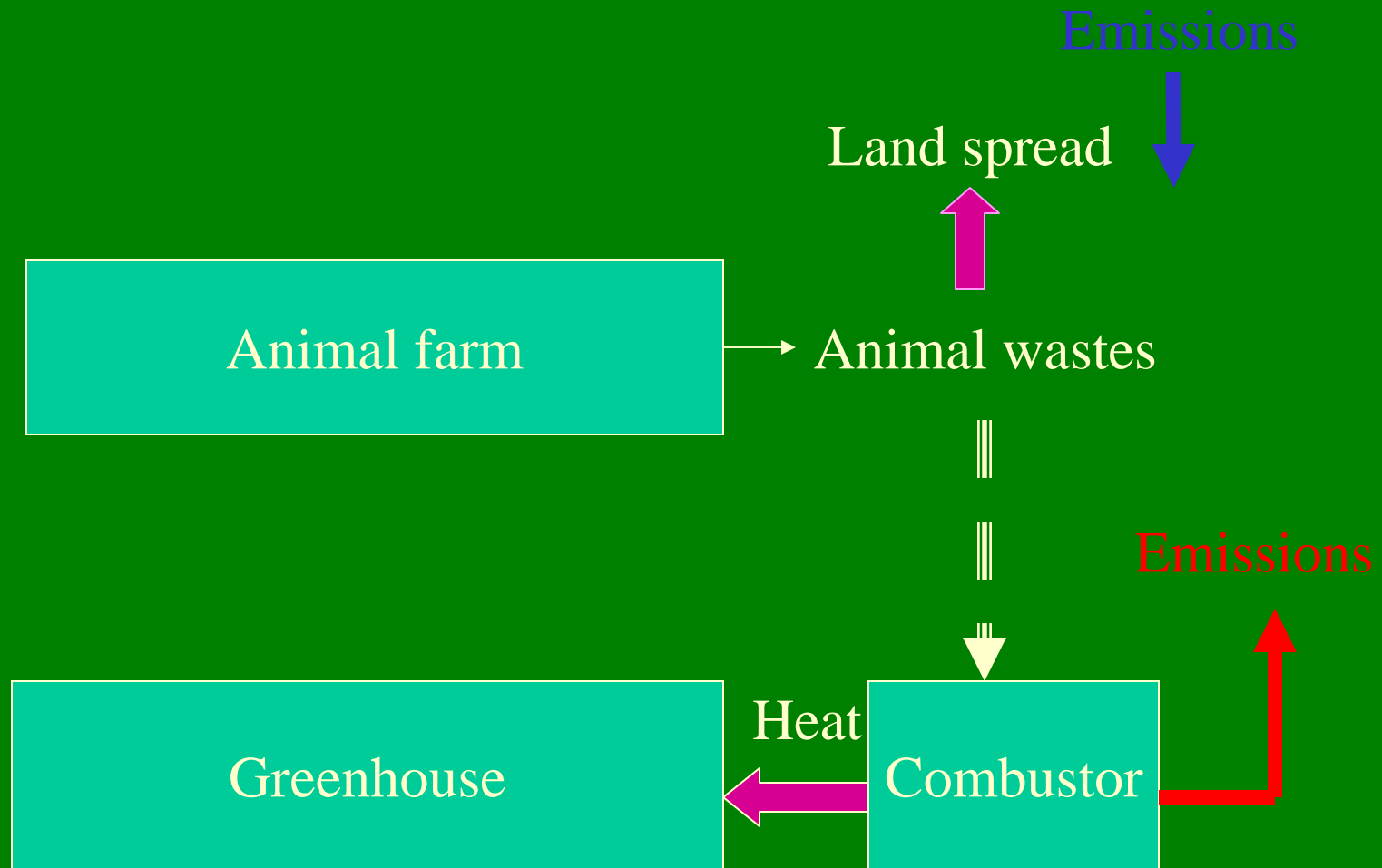

A sustainable engineered agricultural eco-system

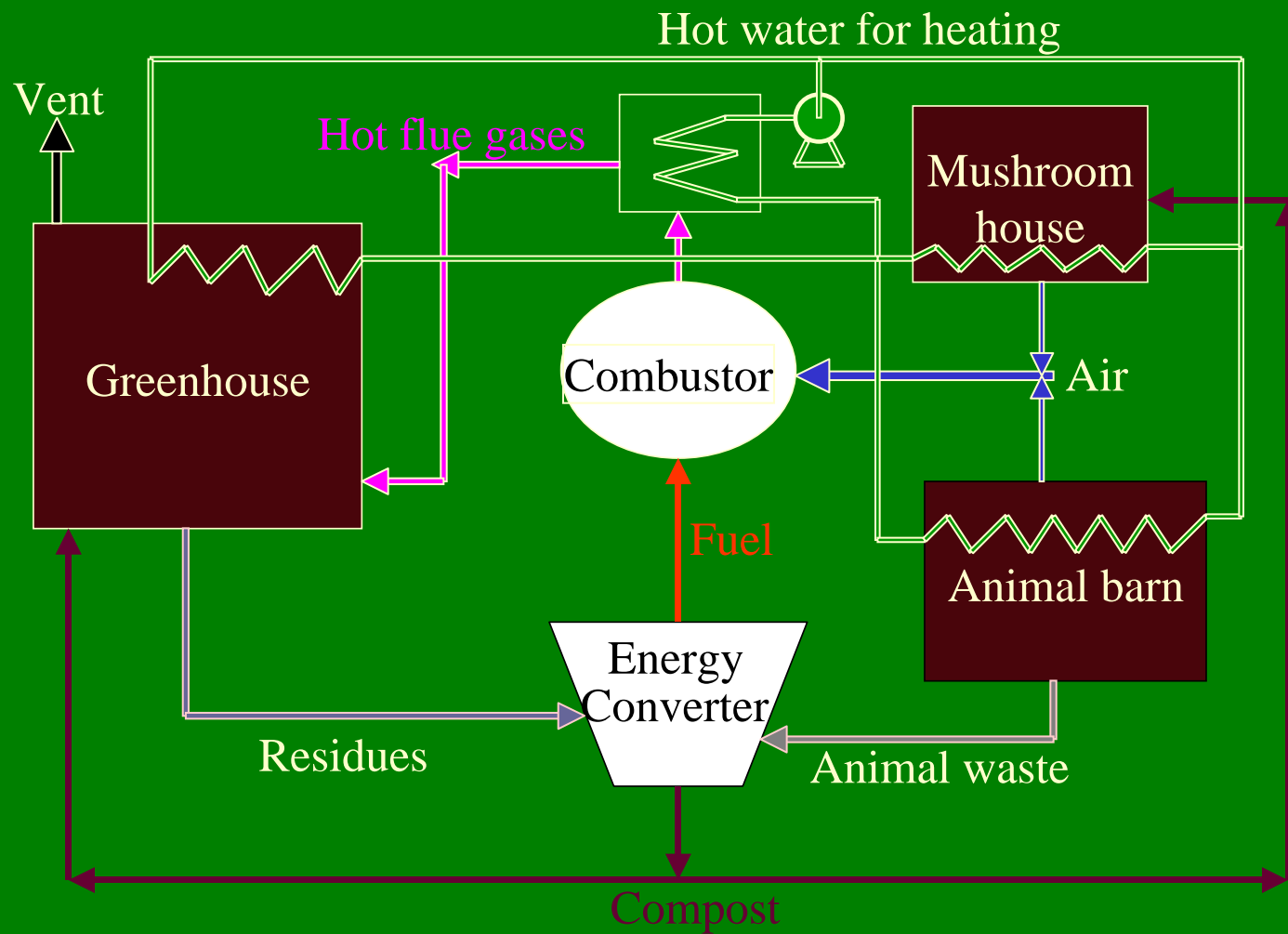

Three supports and three levels

3-Levels

and

3-supports

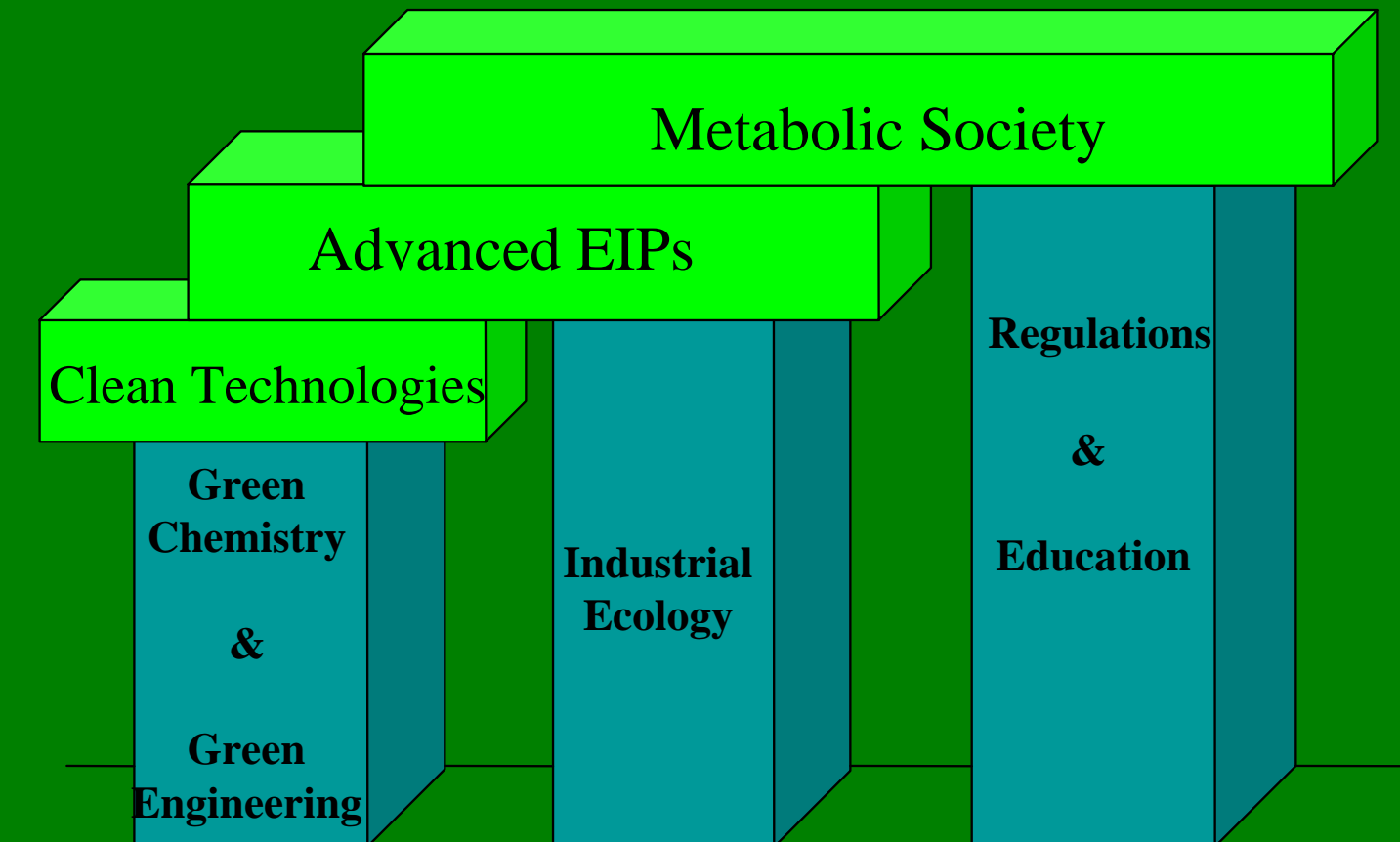

Summary

- ❖ Sustainable development is an urgent task. New technological development is a key for achieving sustainability.
- ❖ The development from clean-up technology through pollution prevention and clean production to green engineering represents a serious paradigm shift.
- ❖ Multiscale approaches are most effective tools for addressing regional and global sustainable development in which the clean technologies are integrated with regional issues across various scales using life cycle thinking and energy and material exchange and integration.

Acknowledgement

- ❖ Natural Sciences and Engineering Research Council of Canada
- ❖ BIOCAP Canada
- ❖ Canada Foundation for Innovation
- ❖ BC Green House Growers' Association
- ❖ ATD Waste Systems Ltd., Vancouver
- ❖ Natural Gas Technologies Centre, Quebec